

PIXIS: 512



The PIXIS: 512 series of cameras from Princeton Instruments are fully integrated, low noise cameras designed expressly for quantitative scientific imaging applications. Choose front-illuminated (F) and back-illuminated versions of the 512 x 512 CCD for true 16-bit performance from UV to NIR wavelength range. Designed based on PI's exclusive XP cooling technology, PIXIS is the only camera in the market that offers cooling up to -80°C and lifetime vacuum guarantee. The all-metal, hermetically sealed vacuum design ensures maintenance free operation for OEM and research applications. This, coupled with high QE and ultra low-noise electronics, PIXIS: 512 can be used for demanding low light level applications such as chemiluminescence and fluorescence. The dual speed operation at 100 kHz or 2MHz means that the camera can be used for steady state as well as fast kinetic studies.

Applications: semiconductor failure analysis, astronomy, photometry, laser beam profiling, luminescence and fluorescence imaging, Bose-Einstein Condensate (BEC)

Features	Benefits
All-metal, hermetic vacuum seals	No out-gassing that compromises vacuum performance
Lifetime vacuum guarantee	Worry free operation
Deep cooling	Low dark noise allows detection of faint signals No need for bulky chilled water circulators CoolCUBE, a compact room temperature coolant circulator is available for vibration sensitive environments
Single vacuum window	No optical losses due to multiple optical surfaces AR coated to match the wavelength of interest
512 x 512 imaging array, 24µm x 24µm pixels	Large full well for true 16-bit dynamic range. Ideal when small changes over a bright background need to be measured
Scientific grade CCD	Low noise, few defects, linear response
Front illuminated CCD (512F) Back illuminated CCD (512B)	Affordable technology for moderate light level applications Highest sensitivity in the visible region Front and Back illuminated CCDs can be coated with proprietary UV coating for enhanced UV sensitivity
Low noise electronics	Best performance for low light level applications
Dual digitizers	Dual-speed digitization allows complete freedom to select between "slow operation" for low noise and highest SNR or "fast operation" for rapid image acquisition
Software selectable system gains	Flexibility to optimize signal-to-noise ratio and dynamic range
Kinetics	Custom readout mode offers microsecond resolution
Flexible ROI/binning	Allows faster frame rate and/or sensitivity
USB2.0 data interface Optional fiber optic interface	Plug-n-play operation. Use it with laptop. Ideal for remote operation
Renowned WinView/Spec software	Powerful, yet easy-to-use software packages for acquisition, display and analysis
PVCAM interface	Universal programming interface for easy custom programming. Compatible with Windows 2000/XP and Linux
LabView® Scientific Imaging ToolKit (SITKTM)	Predefined vis for easy integration of camera controls into large experiment

PIXIS: 512 Specifications

	PIXIS: 512F	PIXIS: 512B
CCD Image Sensor	e2v CCD77-10 front-illuminated, grade 1, AIMO	e2v CCD77-10 back-illuminated, grade 1, AIMO
CCD UV coating	Optional UV coating	
Quantum efficiency	See graphs below	
CCD format	512 x 512 imaging pixels; 24 x 24- μ m pixels; 100% fill factor	
Imaging area	12.3 x 12.3-mm (optically centered)	
Lens mount	Adjustable c-mount with integral 25mm shutter	
Deepest cooling temperature	-80°C typical; -70°C guaranteed, Specified at ambient temperature of +20°C	
Thermo staging precision	\pm 0.05 °C	
Cooling method	Thermoelectric Air (standard); Water cooling option available	
Dark current @-70°C	0.002 e-/p/sec (typical), 0.006 e-/p/sec (max)	
Full well		
Single pixel	350 ke- (typical), 250 ke- (min)	
Output node	700 ke- (typical), 600 ke- (min)	
ADC speed/bits	100kHz/16-bit and 2MHz/16-bit	
System read noise		
@100kHz	5 e- rms (typical), 9 e- rms (max)	
@2MHz	12 e- rms (typical), 18 e- rms (max)	
Vertical shift speed	18 μ sec/row; variable via software	
Non-linearity	<1% @ 100kHz	
Software selectable gains	2.5, 5, 10 e-/ADU; available at all speeds	
Operating systems supported	Windows 2000/XP/Vista; Linux	
Data interface	USB2.0 (5m interface cable provided) Optional Fiberoptic interface is available for remote operation	
I/O signals	Two MCX connectors for programmable frame readout, shutter trigger in	
Operating environment	+5 to +30°C non-condensing	
Certification	CE	
Dimensions	16.59cm (6.53") x 11.81cm (4.65") x 11.38cm (4.48") (L x W x H)	
Weight	2.27 kg (5lb)	

Frame Rate

		Readout Time	
		@ 2 MHz	@ 100 kHz
Binning	1 x 1	152.1 msec	2.52 sec
	2 x 2	77.4 msec	0.7 sec
	4 x 4	41.6 msec	219.3 msec

QE Curve

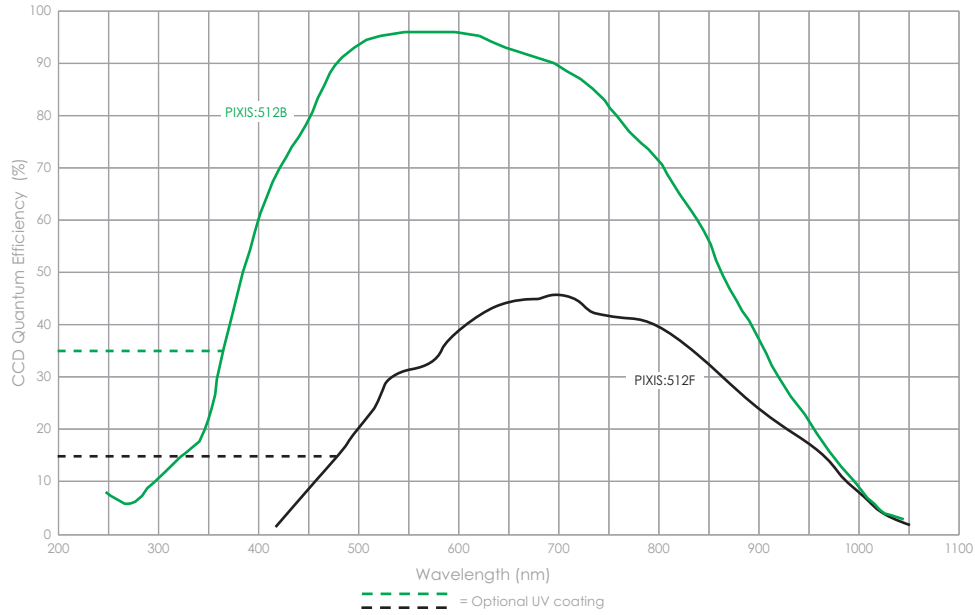

PIXIS: 512 Drawing

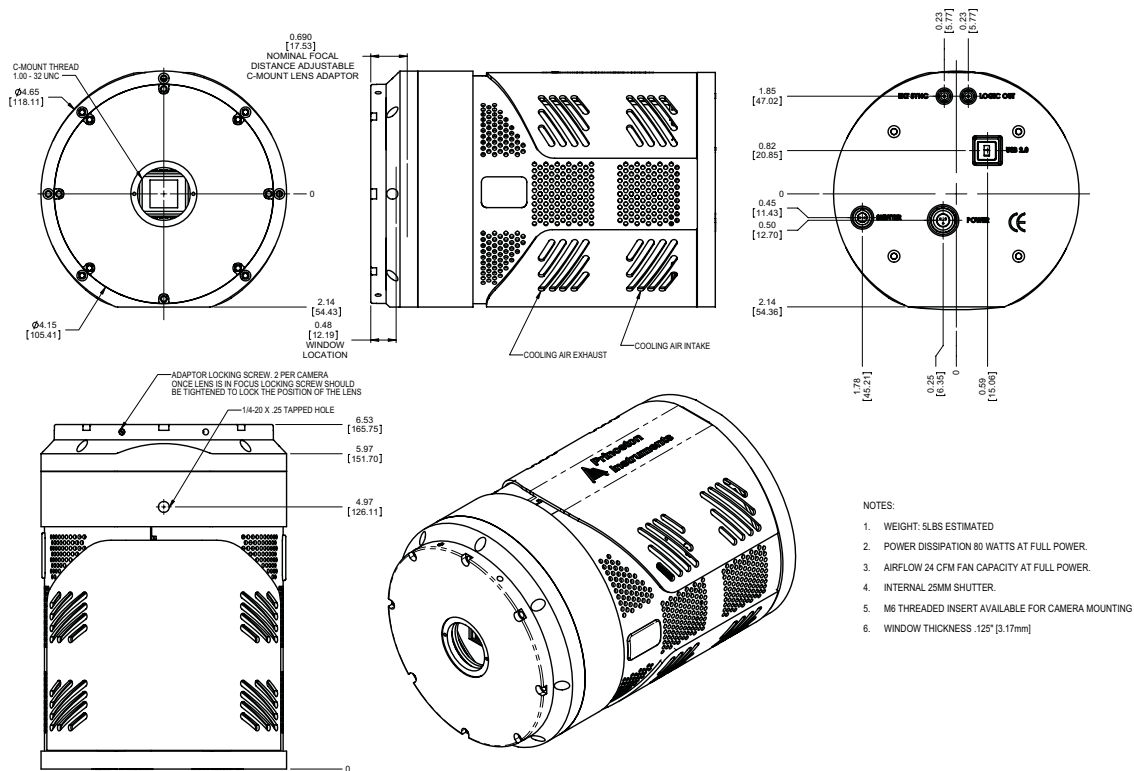

www.piaction.com | moreinfo@piaction.com

USA +1.877.4PIACTON | France +33 (1) 60.86.03.65 | Germany +49 (0) 89.660.779.3
 UK +44 (0) 28.38310171 | Asia/Pacific +65.6293.3130 | China +86 135 0122 8135
 Japan +81.3.5639.2741