

## W-BEAM RAIL

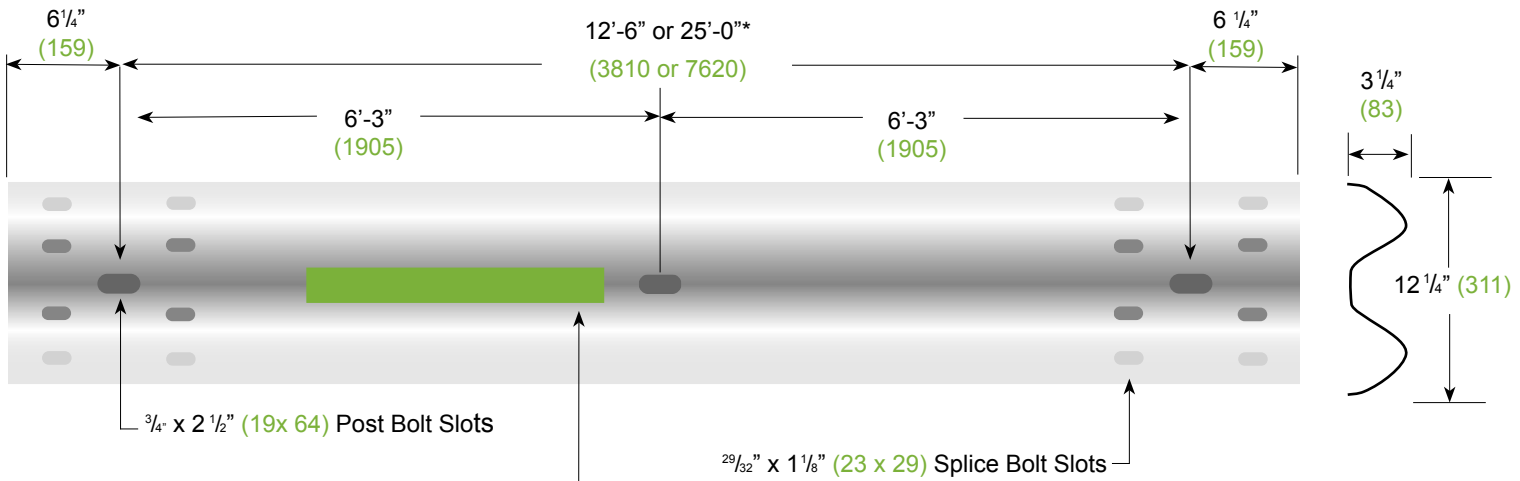

## W-BEAM / THRIE BEAM CENTER PUNCHING

12'-6" (3810 mm)	SPACING	25'-0" (7620 mm)
8G / 208G	12'-6" (3810 mm)	O.C. 58G / 258G
9G / 209G	6'-3" (1905 mm)	O.C. 60G / 260G
11G / 211G	3'-1 1/2" (952 mm)	O.C. 61G / 261G

Part numbers shown for 12 gauge material; 10 gauge part numbers available upon request.

**T** M180 01234567 08 00 A 2

1 2 3 4 5 6

### 1. MANUFACTURER

**T** = Trinity Industries

### 2. AASHTO SPECIFICATIONS

### 3. MILL HEAT NUMBER

08 = Week (8th week)  
00 = Year (2000)

### 5. CLASS

Class A = 12 gauge  
Class B = 10 gauge

### 6. TYPE

Type 1 = Zinc Coated 1.8 oz/ft<sup>2</sup>  
(550 g/m<sup>2</sup>) minimum  
single spot

Type 2 = Zinc Coated 3.6 oz/ft<sup>2</sup>  
(1100 g/m<sup>2</sup>) minimum  
single spot

Type 3 = Uncoated steel

Type 4 = Weathering Steel

## THRIE BEAM RAIL

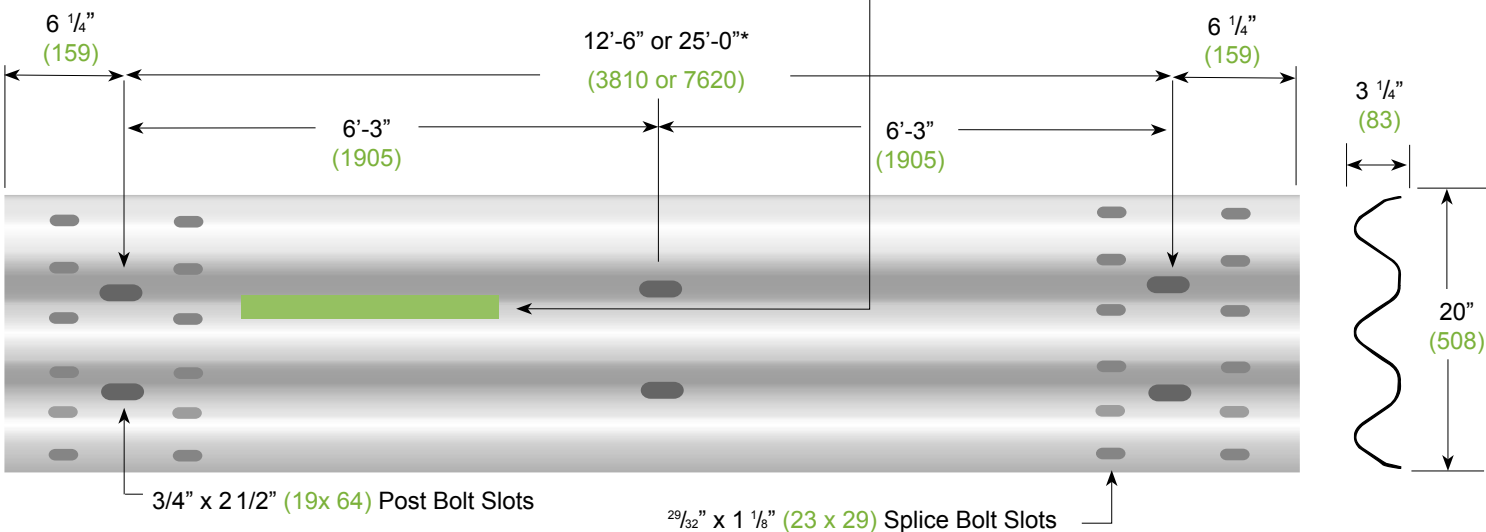

(Metric numbers in green)

## W-BEAM & THRIE BEAM RAIL END SECTIONS

	NOMINAL WEIGHT				
	lbs	kg	lbs	kg	
<b>W-Beam</b>			<b>Thrie-Beam</b>		
901G (12 ga.)	18	8.2	950G (12 ga.)	29	13.2
907G (12 ga.)	22	10.0	957G (12 ga.)	37	16.8
926G (10 ga.)	22	10.0	975G (10 ga.)	37	16.8

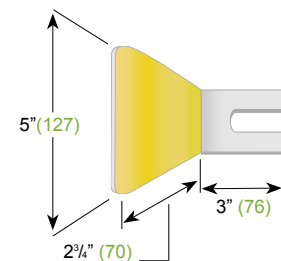

Reflectorized Washer

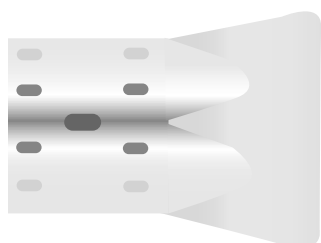

901G



907G

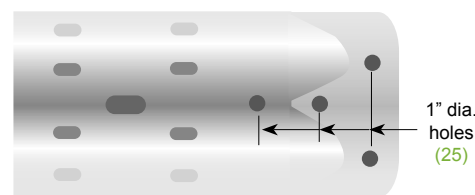

926G (10 ga. only)

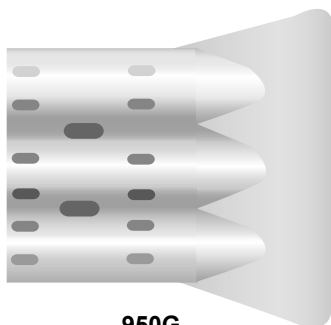

950G

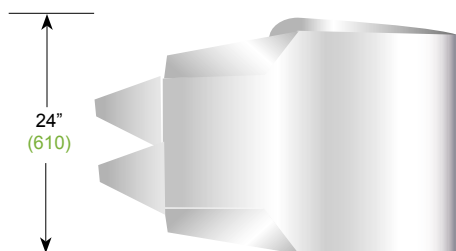

957G

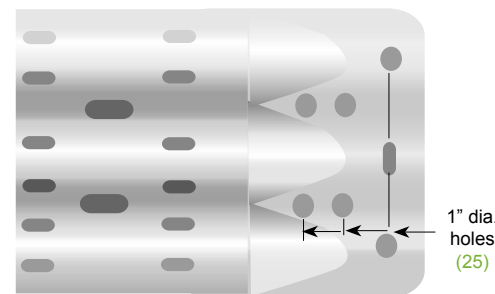

975G (10 ga. only)



End Section (Flared)

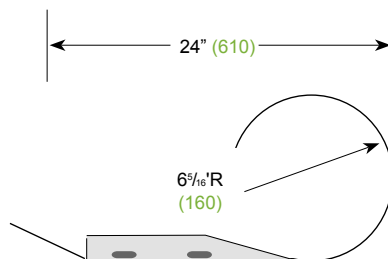

End Section (Rounded)

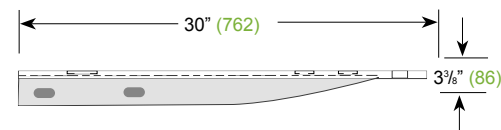

Terminal Connector Parapet

Components are available in 12 gauge or 10 gauge as required (except where noted).  
Finish is available either hot dip galvanized or weathering steel.

## RADIUS RAIL INFORMATION

Rail sections to be installed on curves having a radius of 5 feet (1.5m) to 150 feet (45.7m) can be curved in our fabricating facilities prior to delivery.

Rail can be curved either convex or concave as required. Terms convex or concave refer to the direction curved, outward or inward, relative to the traffic face of the rail.

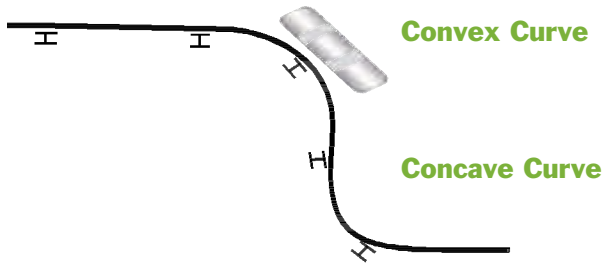

The diagrams & chart provide data for locating posts and curves. For assistance, please contact our Sales Offices.

### TO FIND THE RADIUS FOR A CURVED RAIL:

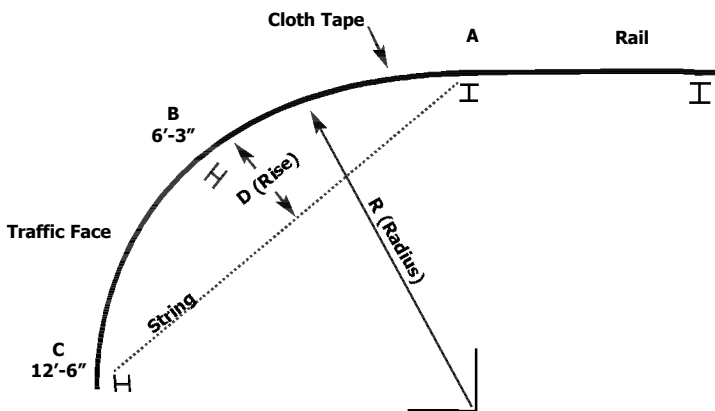

**STEP 1:** Starting at the last post in the straight run (point A), lay cloth tape along the path that the curved guard rail will follow.

**STEP 2:** Mark-off two points along the curved cloth tape: One at 6'3", or 1905 mm (point B) and the second at 12'-6" or 3810 mm (point C).

**STEP 3:** Pull string directly from starting point (point A) to the second mark-off point (point C).

**STEP 4:** Measure from the first mark-off point (point B) over to the mid-point of the taut string. This measurement (D) is the Rise.

**STEP 5:** Check the chart to find the Radius (R), given the Rise (D). Example: a Rise of 4 inches (102 mm) would result in a radius of 60 feet (18.3 m).

*Note: Follow the steps above for each piece of rail section in the curved run. The arc may not be consistent and each consecutive piece of rail may differ in radius from the previous one.*

Rise (D) (Inches)	Radius (R) (Feet)	Rise (D) (MM)	Radius (R) (M)
41	5	1041	1.5
36	6	914	1.8
28	8	711	2.4
26	9	660	2.7
22	10	559	3.1
20	12	508	3.7
18	13	457	4.0
16	15	406	4.6
14	16	356	4.9
11 5/8	20	295	6.1
9 1/2	25	241	7.6
7 3/4	30	197	9.1
6 3/4	35	171	10.7
6	40	152	12.2
5 1/4	45	133	13.7
4 5/8	50	117	15.2
4 1/4	55	108	16.8
4	60	102	18.3
3 5/8	65	92	19.8
3 3/8	70	86	21.3
3 1/4	75	83	22.9
3	80	76	24.4
2 3/4	85	70	25.9
2 5/8	90	67	27.4
2 1/2	95	64	29.0
2 3/8	100	60	30.5
2 1/8	110	54	33.5
2	120	51	36.6
1 3/4	130	44	39.6
1 5/8	140	41	42.7
1 1/2	150	38	45.7

## W-BEAM POST SYSTEMS

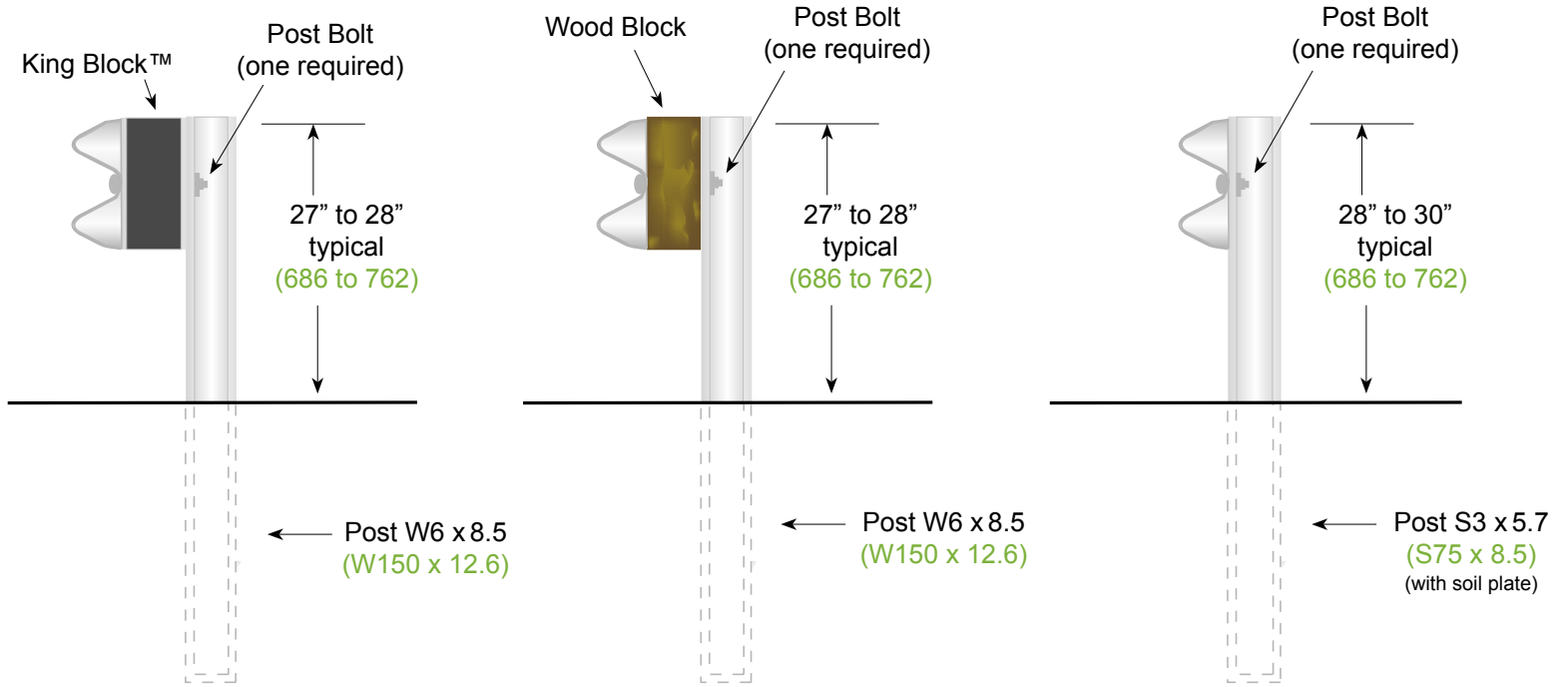

**STRONG POST WITH KING BLOCK™**

**STRONG POST WITH WOOD BLOCK**

**WEAK POST**

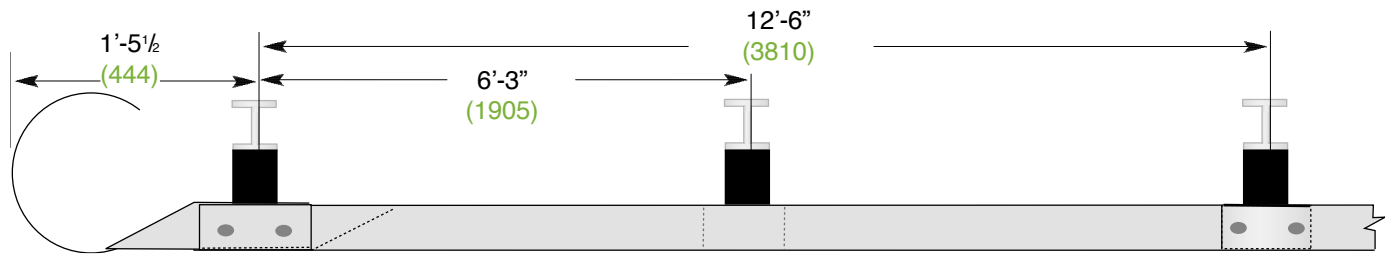

**PLAN**

## THRIE BEAM POST SYSTEMS

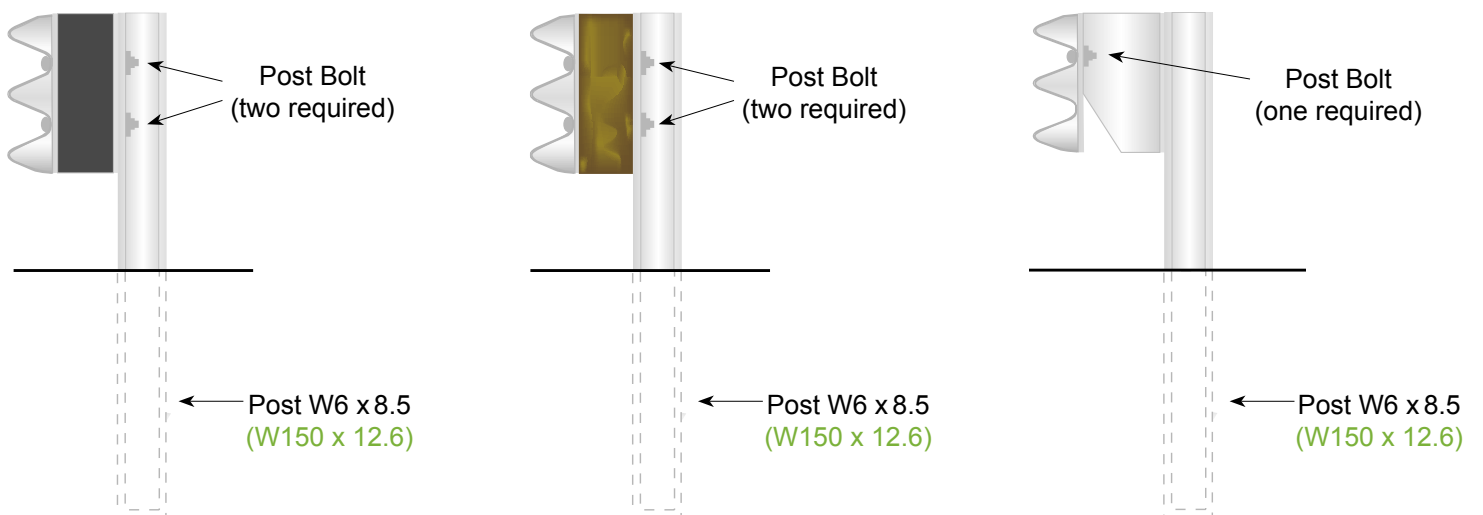

**STRONG POST WITH KING BLOCK**

**STRONG POST WITH WOOD BLOCK**

**STRONG POST WITH MODIFIED STEEL BLOCK (TEST LEVEL 4)**